

PRODUCT CATALOGUE

EasyStands Pull-Ups & Pop-Ups

EasyPopUp®

Engineered for maximum stability

No wonder this is a favourite display system: it's sturdy and compact, light to transport, quick to assemble and it packs a huge graphics punch. Infinitely flexible, its modular design allows you to combine as many panels as your imagination allows in a staggering array of shapes and sizes.

EasyPopUp® is engineered for *longevity.*

Top-quality plastics and aluminium ensure the system retains its structural integrity — exhibition after exhibition. What you display may move on year after year, so your EasyPopUp® is designed for that.

Setting up an EasyStands® pop-up display is child's play. Clip on magnetic bars which ensure total structural stability, then hang panels from hooks at the top of the frame and allow them to fall into place on the vertical magnetic bars, ensuring exact registration between panels. Because we use high-quality, multi-pole magnetic tape on both bars and panels, our customers suffer none of the problems of panel alignment dreaded by users of systems with steel bars.



Our panels stick, and stick in the right place!

Modular design

Is this the most adaptable graphic system available? We think so, and so do those customers — large and small — who appreciate this combination of strength, stability, flexibility and optimum display area. Virtually any length and up to 4.4m high.

STRUCTURALLY STABLE

The high strength to weight ratio of EasyPopUp® means stability: a critical factor, especially for busy, crowded events. It is also strong enough to take extra weight when required, because our magbars make the frame rigid - they don't just stick to it with magnets themselves.

LIGHT

In brightly-lit exhibition halls and shopping malls, you really need to stand out with lighting. EasyStands® lights come with safety approvals - not all others do.

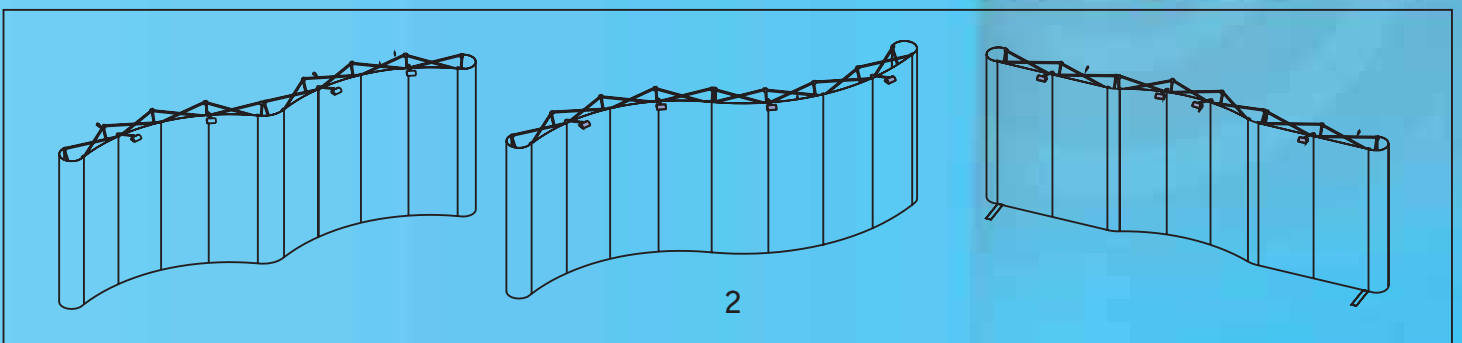



PORTABLE AND PRACTICAL

Complete systems including graphics stow away neatly in a case. The cases have wheels to take the strain and some are designed to double up as freestanding counters you can rest on.

UNINTERRUPTED SURFACE

There's no limit to how big an impression you can make with **EasyPopUp®** displays. Panels join seamlessly and stands can be reconfigured for future events. Use "ghost panels" (with no frame behind) to change direction for continuous graphic walls of unlimited length.

A CHOICE OF HEIGHTS

Standard displays are 2.24m in height, while the retail version is just 1.9m, allowing you to make a big display in height-restricted areas, such as in-store, or in-mall. Each of the two height versions consists of 3 quads (squares) of frame at standard height, and can easily be used at 1, 2, 4, 5 and 6 quads high as well. This means 12 different heights are available, from 66cm up to 4.4m. And when your requirements change, your stand can change.

PANELS

EasyPopUp® accommodates graphic panels or fabric panels — allowing you to mount separate graphics to designs of your choice, using self-adhesive hooktape for ultimate flexibility — change your display in seconds, as often as you like, at no extra cost!

EASILY RECONFIGURABLE

The same kit can be added to at any time — used and re-used in different designs, simply by making modifications with nothing more than a screwdriver. That's why we use screws, not rivets, which also means every component is field-repairable, if damaged.

JOINING KITS TOGETHER?

Ask about "ghost panels" — the industry's best-kept secret. We expect people who sell our stands with their graphics to offer top-quality professional advice to their customers. If you're not getting it, speak to us and we'll provide it, free.

Magnetic EasyPopUp®

EasyPopUp® evolution you might call it, because of a natural progression from the legendary standard model to the same thing with magnetically self-locking frame, and magnetically attaching magnetic (*channel*) bars.

Amongst the advantages of this model are complete compatibility with the original model, meaning components are interchangeable, and the same panels fit both systems. We've added more speed of assembly, that's all, following a trend we freely admit evolved without us.

Magnetic EasyPopUp® addresses that trend, yet by careful design it retains most of the advantages of its predecessor, and because we make it in our new factory in Asia, it is great value for money.



This Conference backdrop is 13 metres long by 3 metres high, with 48m² of graphic display, transports in just 6 wheeled cases, and assembles in less than 2 hours, by 2 people with one stepladder.



*With an odd stand floor area of 7.5 x 4 metres to occupy, this customer chose an **EasyPopUp®** system which assembled in under an hour by one person with no tools, completely avoiding the need to hire on-site contractors. An important consideration these days.*



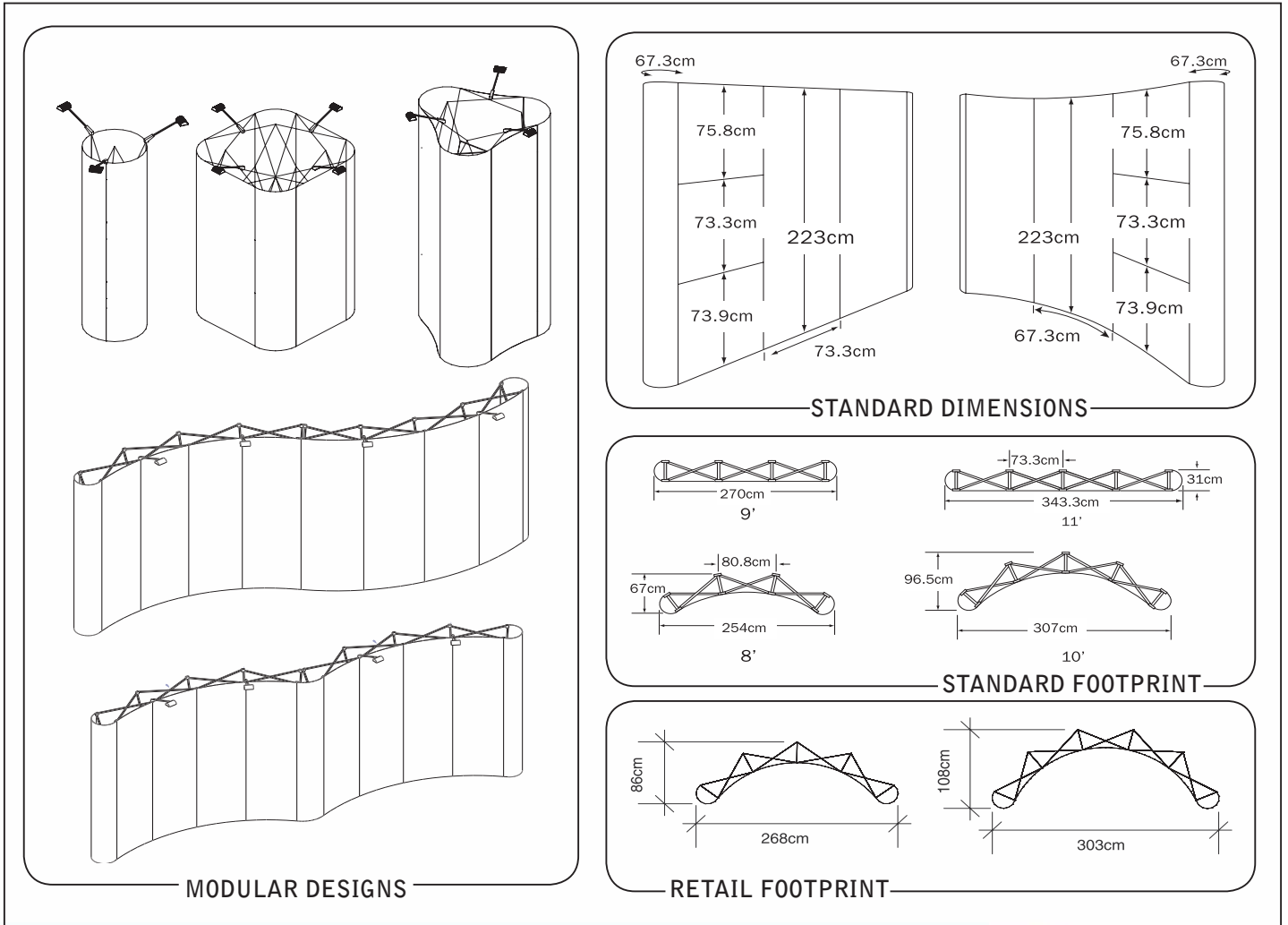

INTERNAL SHOWCASE

Giving products a real presence on your stand is easily achieved by integrating a showcase. A full 73.3 cm of height allows you to build in shelves, either angled for literature or flat for product display. Extra visual impact comes from optional built-in downlighting.

Showcases are available for both curved AND straight frames.

HEIGHT: 73.3cm, WIDTH: As panels, DEPTH: 31.0cm



PANEL OPTIONS

Whilst graphic panels are most popular today for greater visual impact, those with constantly-changing displays may prefer the enormous flexibility and economy of applying graphics of any size and shape with hooktape to our beautiful fabric panels.

You can even hang lightweight products on the stand in the same way in seconds! With both stock and non-stock colours available there is a large choice on offer.

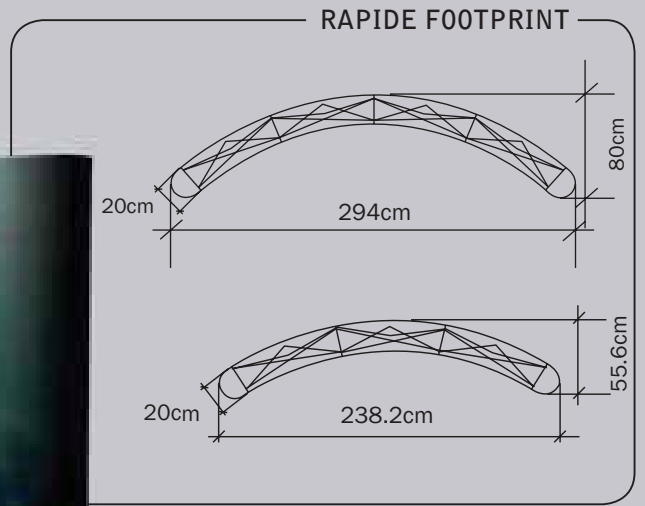

The **Rapide EasyPopUp®** is available with narrow end panels (shown above), and with full-width end panels as well, which adds about 20cm to the footprint, at each end.

Rapide EasyPopUp®

The Ultimate in graphic display speed, this MECHANICALLY self-locking frame, with self-attaching magnetic channel bars, and self-attaching panels, means anyone putting up this stand is hardly more than a guiding hand - almost a spectator!

We believe that **Rapide EasyPopUp®** is the finest example there is of state-of-the-art in our industry, and also by far the best value for money on offer in the world today.



Rapide Hub

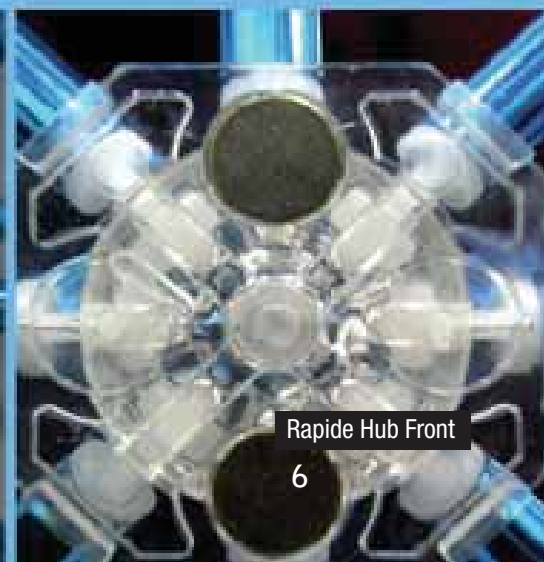

Rapide Hub Front

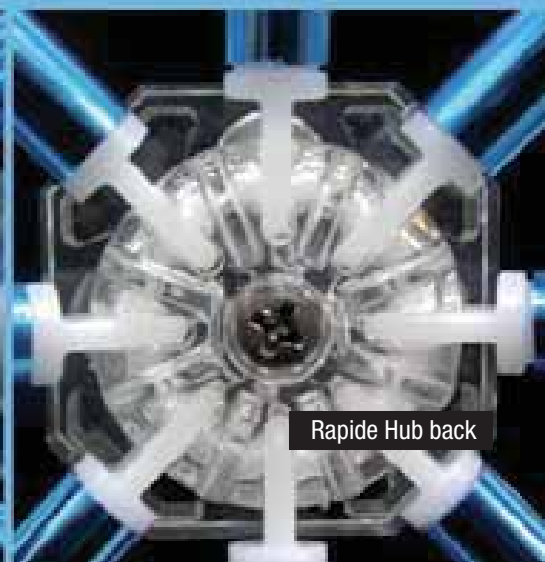

Rapide Hub back

EasyPopUp® Accessories

EasyLight™

The halogen floodlight gives light over a large surface area. With hub or scissor bracket options when you order, you choose where the lights go.



Single light bag



Double light bag



Halogen Floodlight



Deluxe

Maxi

Oval

Economy

Trolley Bag

EasyCase™

Cases are available in different sizes with wheels for ease of use — providing protection for your display stand and graphics while in transit, and most usefully doubling as a counter.



Optional Folding Counter Top

PANEL MOUNTINGS

Two key components ensure display panels fit easily and firmly into place. A top hookstrip (hanger) neatly secures the panel onto the frame, and multi-pole magtape marries panel and magbar together for a perfect fit with the next one all the way to the bottom. Accurate graphic registration is designed-into **EasyPopUp®**.

Flimsy panels don't perform and they don't last! Our specification ensures that they do both. We supply panel care stickers on every panel to ensure you know how to look after them.



PVC Roll



Magtape



HookStrip

EasyDrum™

Offers a lower-cost option for smaller kits and additional panels. Lighter in weight, they are convenient to transport.



Retractable Banners

CUSTOM SIZES
OF ALL OUR STANDS
ARE AVAILABLE TO ORDER.

EasyRoll Banner®

Longer lasting - guaranteed

This is a real display winner. Engineered to a very high standard for rock solid, reliable use year after year, **EasyRoll Banner®** will outlast any number of campaigns. Unlimited graphic changes are designed into this stand. At the heart of the **EasyRoll Banner®** is a powerful, spring-powered motor.

The base — weighted to perfection — is made from quality aluminium and sits firmly on the floor as you draw out the graphic and hook it onto the end of a collapsible pole. Wider sizes use more than one pole.

If you want extra display for a fraction more cost, then specify a twin-motor stand. The same stand carries one or two banners and a single can be easily converted to a twin later.

ROBUST CONSTRUCTION

EasyRoll Banner® is the workhorse of many marketing departments. Year after year they are taken to event after event and expected to perform perfectly. Pivotal to this proven reliability is a hugely robust, spring-powered motor in a quality aluminium housing which is substantially thicker than many copy-cat products. Give it a tap and you'll *hear* the difference.

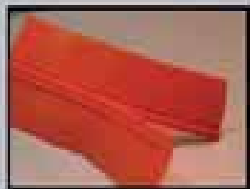

Zip



Velcro®

EasyChange™ banner mountings are a great favourite, enabling you to change banners in the field, without returning a stand to your printer, or having to pay so much extra for replacement “cassettes” which some people sell. Velcro® or Zip attachments make banner changes so easy that anyone can do it in almost no time at all, anywhere, anytime. ALL our retractable stands can be fitted with either version, ensuring banners can be changed at almost no cost at all.

LIGHT

One Size fits all - any of our banner stand models and every size of each. What could be **Easier™**?



STABLE AND EFFICIENT

Its solid base is designed for a low centre of gravity, without the need for additional support feet. At a floor depth of only 23cm this stand occupies almost HALF the space of cheaper options which need swing-out feet to stay upright (*ours included.*) Where floorspace is at a premium, **EasyRoll Banner®** is a clear winner.



SINGLE OR TWIN?

The choice is yours. Double your display area for a fraction more cost by ordering a twin unit — with two spring motors in the same base. Or start with a single and change it to a twin later.

Twin conversion kits are always available.

BAGS

Padded carry bag and substantial 5-ply box hold your **EasyRoll Banner®** neatly and safely, while for those that will be seeing more than their fair share of travelling, there is also a flight case available. It might even reduce your insurance premium?

85cm **EasyRoll Banner®** in padded bag weighs under 7kg with one banner and under 8kg with two. *(Box and case add extra weight.)*

Our bags show you which GRAPHIC is in there with a mini print!



EasyBanner® Retractable

If you can't afford our top-of-the-range stand, this model is the next-best thing for those who don't like the look of swing-out feet, or the extra floorspace which they occupy.

This is a solid stand made from thick aluminium with plastic trim, offering presentable appearance at a low price because of its relative simplicity.

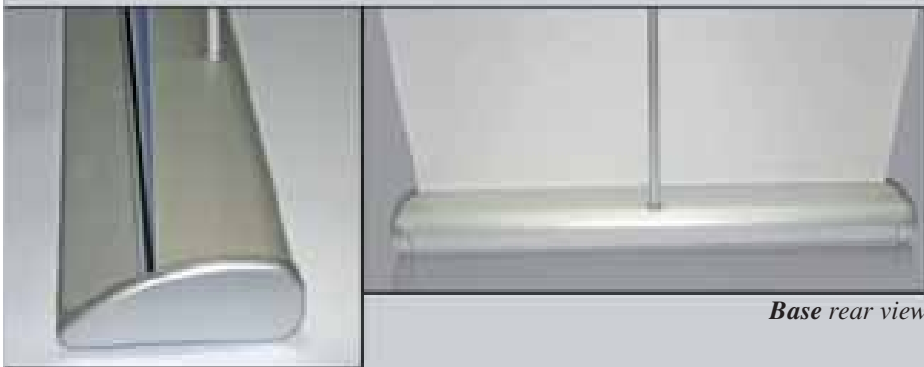

Base side view

Base rear view



Quick+Easy RollUp™

More **Quality** for your money

Simple, light, flexible and so easy to use. But while it's convenient and modestly priced, **Quick+Easy RollUp™** makes no compromise on quality.

This is a retractable banner stand manufactured in thick aluminium at a real budget price, and its sturdy, proven design and reliable mechanism mean you can re-use it time and again, year after year.

The swing-out foot provides stability, whilst the thickness of the aluminium used throughout is greater than many others to earn our guarantee of performance.



EasyBanner® Cassette

The **fastest change** in the industry

For those who need to change campaigns at multiple locations, nightmares can result. Returning stands to your printer and then re-delivering costs far too much. Not with this model, because we've made it so easy to achieve at minimal cost WITHOUT returning the stands.

YOU CHOOSE.

- Replace cassette + rail on site.
- Replace cassette only on site + swap the rail to the new banner.
- Replace banner only on site, swapping the rail, using **EasyChange™** banner mounting.
- Re-graphic at the lowest cost, anywhere, by anyone!



Bagged and boxed by us for you, carry it or ship it – it's all the same to us.

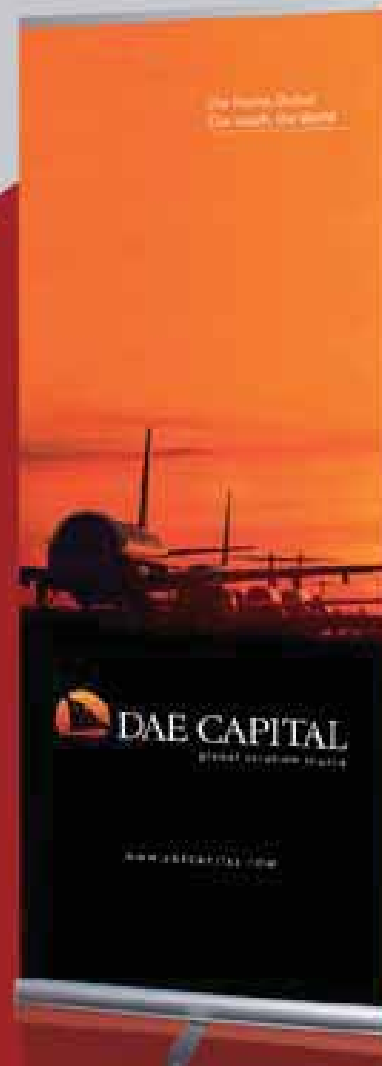

Low-Price RollUp™

The **optimum** economy option

Originally introduced as our cheapest model, and hugely popular for many years because of its very high performance to price ratio, always out-performing its rivals in this price bracket, the introduction of an even cheaper model for the first time in 2009 enabled us to upgrade **Low-Price RollUp™** in a number of very important ways, in common with our better models.

- Strong steel end-plates replaced weaker aluminium
- Stronger spring motor
- Hookless snap rail with no breakable plastic pole-top
- New dies produce thicker extrusions for the body

The resulting increased rigidity and strength of the stand enables a single stabilising foot which improves appearance, and it will happily take the extra weight of outdoor solvent-printed banners AND a light, without leaning. Many stands which LOOK the same will not.

A change from carry bag to carry box enabled us to maintain pricing to ensure that this stand now performs even further above its class.

The bag shown is optional and supplied separately, as is a separate box without handle to transport the stand when in a bag.



Cheap RollUp

The **maximum** economy option

In response to customer demands for cheaper and cheaper stands, this model achieves that by using thin aluminium and thin anodising to reduce cost, yet still benefits from our powerful standard motor. When price is all that matters, this is the one for you.

Packing in thin bags which provide almost no protection ensures as many as possible can be stuffed into a container, in boxes of 6, reducing shipping cost to a minimum as well.

The cost-savings achieved make this model unavoidably weaker and more vulnerable to damage, and padded bags and single stand boxes are only available separately.

The labour-intensive wrap-rail can be upgraded at an extra cost to our hookless snap-rail.



WIDER AND WIDER

EasyBanner® can be seamlessly connected to give unbroken graphics — easily transportable and very cost effective.

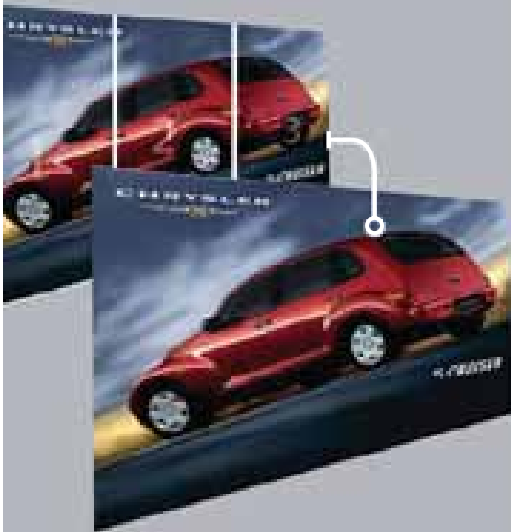

To achieve this you will need **EasyJoin™** — simply ask for details when ordering.

EasyBanner®

Portable, stable and very, very practical

This is a hugely popular model — and it's easy to see why. Either standard or telescopic poles are simplicity itself to use and your graphic is quite separate, letting you change your promotional message as often as you want. Simply change **EasyRail™** from the old to the new graphic and it's ready to go up — by untrained staff, anywhere at all. With no moving parts there really is nothing which can go wrong with such a simple stand. Our flat steel base is no accident. It provides very much more stability than many prettier ones we've seen, and helps explain the popularity of **EasyBanner®** over many years.

Once the stand is working for you on location, all you have to do is send new promotional graphics — weighing less than 1 kg — to refresh your campaign.

Banner width of 85cm unless you want wider.

And you can choose the height...

Standard height of 215cm or less can be infinitely flexible with the telescopic pole option. Fixed height for ease of use or variable for changing requirements.



EasyBanner® Lite

Cheap and cheerful banner display for those on a tight budget. The Standard size of 80 x 180cm can easily be customised smaller before mounting the graphic.

A little more labour-intensive for mounters than stands which cost more, it does a perfectly acceptable job for those on a very low budget.

X-Banner

Another cheap banner display for those with enough floorspace available. Our mounting hooks are much faster to use than screw-fittings used by some others.

They don't look very nice, and they take up a lot of room, but you get what you pay for, and you don't pay much for these.



FlyingBanner

What works best - simple or complicated? We think simple, and so do many graphics printers and mounters tasked with making flying / teardrop / wind dancer banners of weird and wonderful shapes.

Rectangular banners maximise layout possibilities, minimise production time and wastage, and mounters love them for their simplicity.

Being square can be cool.



WaterFlag

For an even bigger impact, this 4m high banner on a 5m telescopic pole, is held down by a water-filled base, which is segmented and empties for ease of transport.

Literature Stands

EasyBrochure™

roll-up literature display

A light, simple and cost-effective solution to displaying your literature at events. Only 55cm long in its compact travel bag, our literature display stand is as portable as it gets.



EasyFold™

Clearly a better way to display and dispense your literature

This proven favourite is the ultimate in portability. It does what it says — unfolding easily, complete with literature already loaded, to provide a brochure dispenser for instant action. And you won't have to keep filling it too often as it holds a lot of literature in its 4cm deep pockets! A4 or US letter. Maximum visibility for your literature.

CLEAR DISPLAY

Its clear acrylic pockets make sure your prospects are looking at your literature, and NOT at what is holding it.

PORTABLE?

Fold complete with literature to ensure the fastest getaway yet. Supplied in its own permanent shipping and carry box for protection. We can't make paper any lighter, but using aluminium keeps the weight of **Easyfold™** itself down to under 4kg.



A-Board

An Industry standard which has been around for a very long time. Stocked in A1 double sided and in the extended version shown here with the header panel added.



SnapFrame

So simple to make that almost anyone can do it, as you may have seen, and our manufacturing quality may be considered superfluous by most users and re-sellers.

Snap Frames have become a low-tech commodity product in our industry to the extent that our quality is available only to order in bulk quantities shipped directly from our Shanghai factory.

Mitred or rounded plastic corners are available.



PosterStand

Portrait or landscape rotating head on telescopic pole from 1.3m down. Available in A4 and A3 sizes from stock.





THE DISPLAY EXPERTS



JJ Copyprint

49 Station Road
Winchmore Hill
London N21 3NB
020-8360 9403
Fax 020-8364 0222
studio@jjcopyprint.com
www.JJCopyprint.com

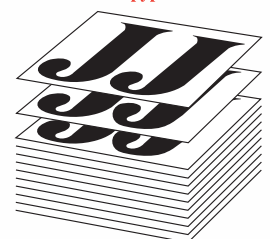

Another great idea from JJ Copyprint